

SECTION A-A

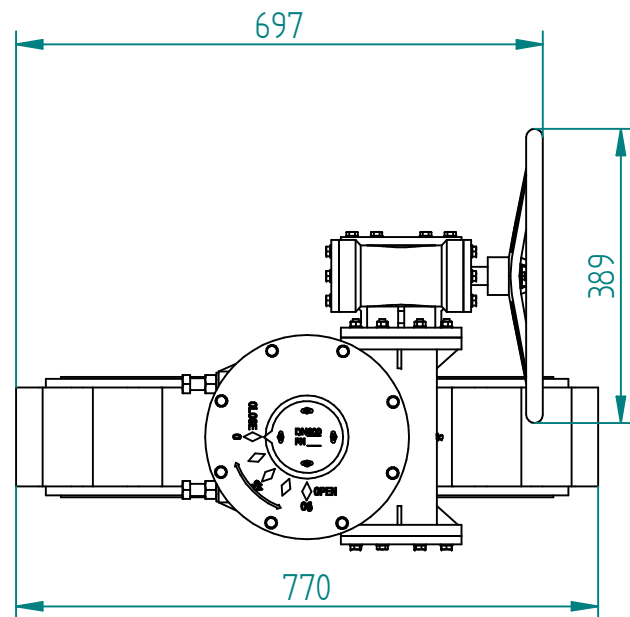

POS	Item number	Material	Quantity
1	Body	Iron:0.7040 , EN-GJS-400-15 Ceramic	1
2	Short-Bushing	PTFE (Polytetrafluoroethylene)	2
3	Long-Bushing	PTFE (Polytetrafluoroethylene)	2
4	O-Ring	NBR (Nitrile Butadiene Rubber)	1
5	Seat	EPDM (Ethylene Propylene Diene Monomer)	1
6	Disc	Iron:0.7040 , EN-GJS-400-15 Ceramic	1
7	Top-Shaft	Stainless Steel, 416	1
8	Bottom-Shaft	Stainless Steel, 416	1
9	End-Cap	Iron:0.7040 , EN-GJS-400-15	1
10	Stop-Cover	Galvanized steel	1
11	End-Cap-Screw	Galvanized steel	2
12	Stop-Cover-Screw	Galvanized steel	4
13	Stop-Cover-Lock-Washer	Galvanized steel	2
14	Stop-Cover-Washer	Galvanized steel	2
15	QIF-320-009-4000		1

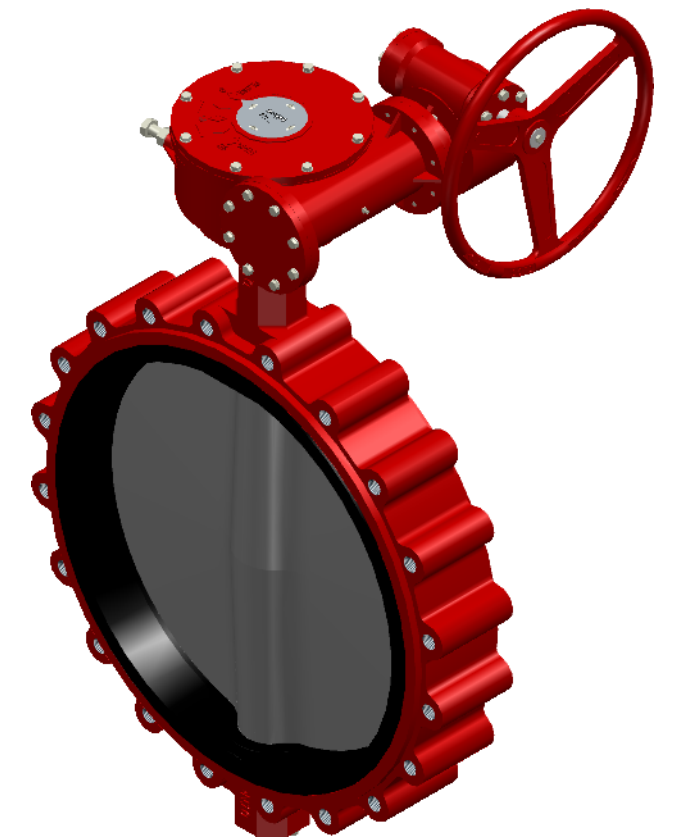

TITLE	NAME		DATE	SIZE	DWG NO
	DRAWN	AXJO	12.05.2026	<b>A3</b>	AMX-110-062-0600
	CHECKED	TOCO	dd.mm.yyyy	FILE NAME: AMX-110-062-0600.dft	
	ENG APPR	TOCO	dd.mm.yyyy	SCALE: 1:10	REV: 00
	MGR APPR	TOCO	dd.mm.yyyy	WEIGHT: 174,649 kg	SHEET: 1 OF 1

GA-Drawing and Parts List

UNLESS OTHERWISE SPECIFIED DIMENSIONS ARE IN MILLIMETERS AND TOLERANCES ARE +/-0,5

REV	DESCRIPTION	DATE	APPROVED
00	First issue	12.05.2026	AXJO
REVISION HISTORY			