

POS	Item number	Material	Quantity
1	Body	Iron:0.7040 , EN-GJS-400-15 Ceramic	1
2	Short-Bushing	Galvanized steel	2
3	Long_bushing	PTFE (Polytetrafluoroethylene)	2
4	O-Ring	NBR (Nitrile Butadiene Rubber)	1
5	Seat	EPDM (Ethylene Propylene Diene Monomer)	1
6	Disc	Iron:0.7040 , EN-GJS-400-15 Ceramic	1
7	Top-Shaft	Stainless Steel, 416	1
8	Stop-Cover	Galvanized steel	1
9	Bottom-Shaft	Stainless Steel, 416	1
10	End-Cap	Iron:0.7040 , EN-GJS-400-15	1
11	End-Cap-Screw	Galvanized steel	2
12	Stop-Cover-Screw	Galvanized steel	5
13	QIF-320-007-2500		1

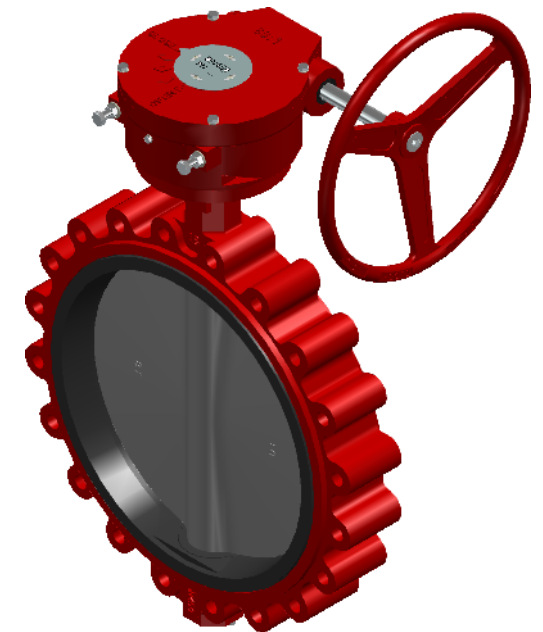
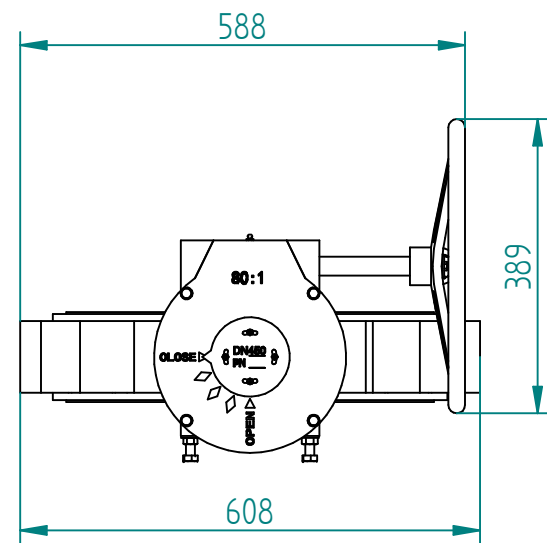

TITLE GA-Drawing and Parts List

	NAME	DATE	SIZE	DWG NO
DRAWN	AXJO	12.05.2026	A3	AMX-110-062-0450
CHECKED	TOCO	dd.mm.yyyy	FILE NAME: AMX-110-062-0450.dft	
ENG APPR	TOCO	dd.mm.yyyy	SCALE: 1:10	REV: 00
MGR APPR	TOCO	dd.mm.yyyy	WEIGHT: 35,904 kg	SHEET: 1 OF 1

UNLESS OTHERWISE SPECIFIED DIMENSIONS ARE IN MILLIMETERS AND TOLERANCES ARE +/-0,5

REV	DESCRIPTION	DATE	APPROVED
00	First issue	12.05.2026	AXJO
REVISION HISTORY			