

POS	Item number	Material	Quantity
1	Short-Bushing	PTFE (Polytetrafluoroethylene)	2
2	Body	Iron:0.7040 , EN-GJS-400-15	1
3	Long-Bushing	PTFE (Polytetrafluoroethylene)	2
4	O-Ring	NBR (Nitrile Butadiene Rubber)	1
5	Seat	EPDM (Ethylene Propylene Diene Monomer)	1
6	Disc	Iron:0.7040 , EN-GJS-400-15 Ceramic	1
7	Upper-Shaft	Stainless Steel, 416	1
8	Stop-Cover	Galvanized steel	1
9	Lower-Shaft	Stainless Steel, 416	1
10	Screw	Galvanized steel	2
11	QIF-320-005-0500		1

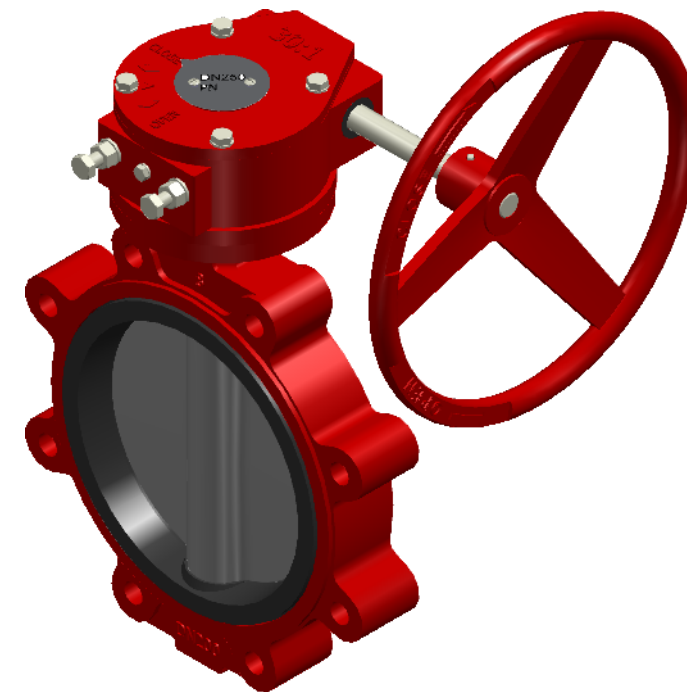
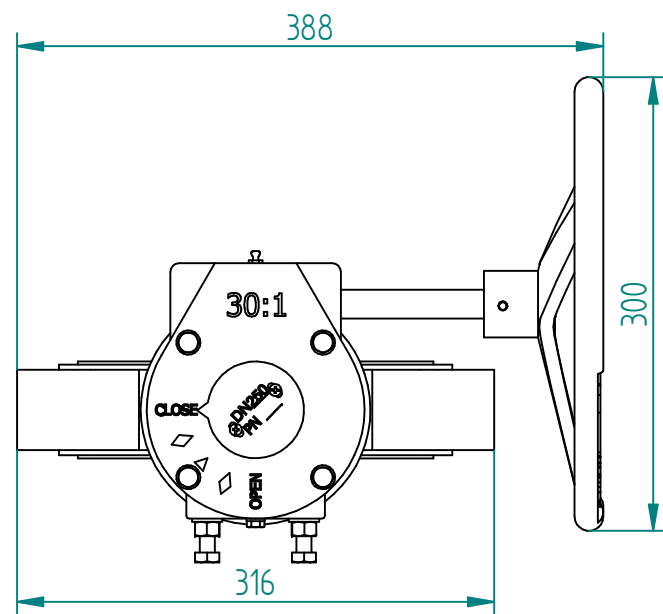

TITLE	NAME		DATE	SIZE	DWG NO
	DRAWN	AXJO	12.05.2026	A3	AMX-110-062-0200
	CHECKED	TOCO	dd.mm.yyyy	FILE NAME: AMX-110-062-0200.dft	
	ENG APPR	TOCO	dd.mm.yyyy	SCALE: 1:5	REV: 00
MGR APPR	TOCO	dd.mm.yyyy	WEIGHT: 16,661 kg	SHEET: 1 OF 1	

UNLESS OTHERWISE SPECIFIED DIMENSIONS ARE IN MILLIMETERS AND TOLERANCES ARE +/-0,5

REV	DESCRIPTION	DATE	APPROVED
00	First issue	12.05.2026	AXJO
REVISION HISTORY			