

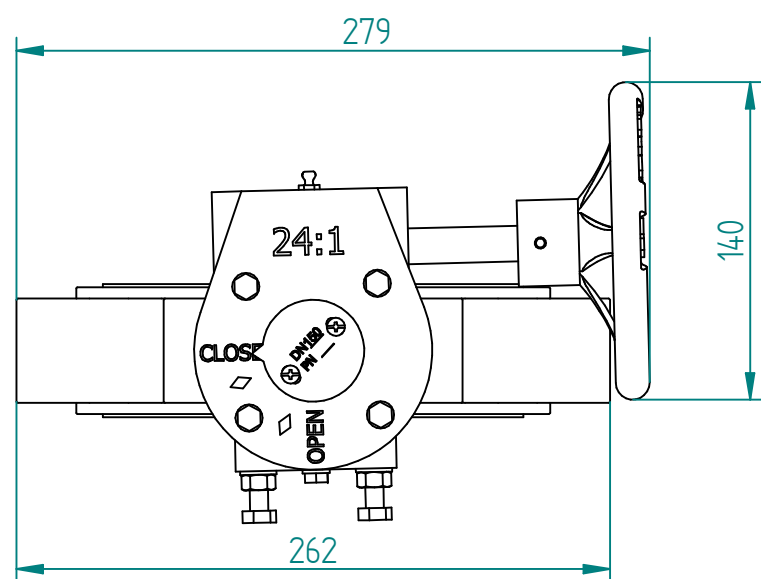

POS	Item number	Material	Quantity
1	Seat	EPDM (Ethylene Propylene Diene Monomer)	1
2	Body	Iron:0.7040 , EN-GJS-400-15 Ceramic	1
3	Disc	Iron:0.7040 , EN-GJS-400-15 Ceramic	1
4	Stem-Top	Stainless Steel, 416	1
5	Long-Bushing	PTFE (Polytetrafluoroethylene)	2
6	Short-Bushing	PTFE (Polytetrafluoroethylene)	2
7	O-Ring	NBR (Nitrile Butadiene Rubber)	1
8	Stop-Cover	Galvanized steel	1
9	Stem-Bottom	Stainless Steel, 416	1
10	Screw	Galvanized steel	2
11	QIF-320-004-0150		1

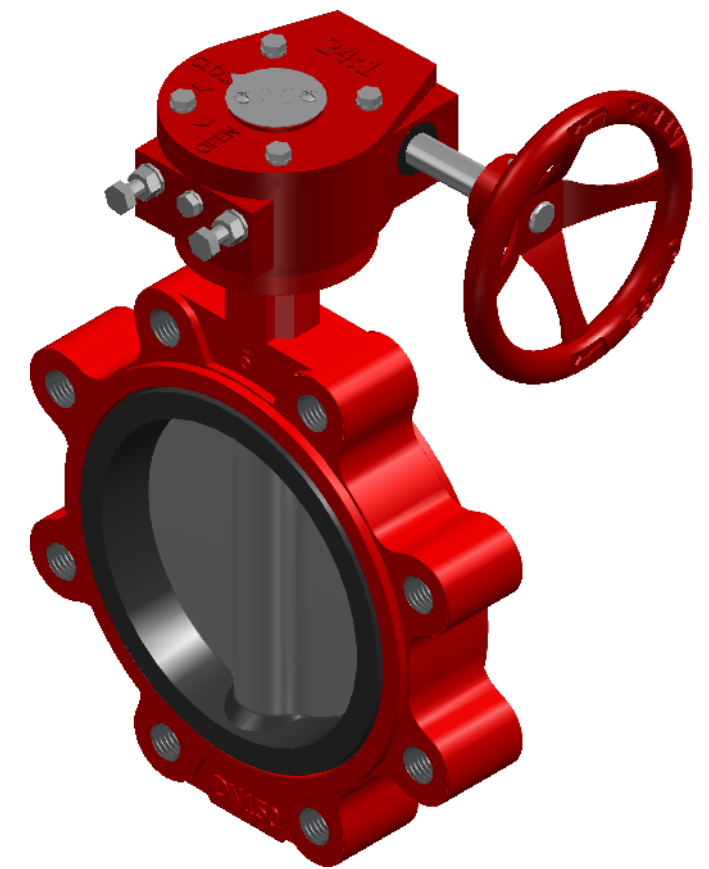

	NAME	DATE	SIZE	DWG NO
	DRAWN AXJO	15.05.2026	A3	AMX-110-062-0150
	CHECKED TOCO	dd.mm.yyyy	FILE NAME: AMX-110-062-0150.dft	
	ENG APPR TOCO	dd.mm.yyyy	SCALE: 1:3,33	REV: 00
MGR APPR TOCO	dd.mm.yyyy	WEIGHT: 10,119 kg	SHEET: 1 OF 1	

UNLESS OTHERWISE SPECIFIED DIMENSIONS ARE IN MILLIMETERS AND TOLERANCES ARE +/-0,5

REV	DESCRIPTION	DATE	APPROVED
00	First issue	15.05.2026	AXJO
REVISION HISTORY			

TITLE GA-Drawing and Parts List