

| POS | Item number | Material | Quantity |
|-----|---------------|-----------------------------------------|----------|
| 1 | Seat | EPDM (Ethylene Propylene Diene Monomer) | 1 |
| 2 | Body | Iron:0.7040 , EN-GJS-400-15 Ceramic | 1 |
| 3 | Disc | Iron:0.7040 , EN-GJS-400-15 Ceramic | 1 |
| 4 | Stem-Top | Stainless Steel, 416 | 1 |
| 5 | Long-Bushing | PTFE (Polytetrafluoroethylene) | 2 |
| 6 | Short-Bushing | PTFE (Polytetrafluoroethylene) | 2 |
| 7 | O-Ring | NBR (Nitrile Butadiene Rubber) | 1 |
| 8 | Stop-Cover | Galvanized steel | 1 |
| 9 | Stem-Bottom | Stainless Steel, 416 | 1 |
| 10 | Screw | Galvanized steel | 2 |
| 11 | QIF-320-L05 | | 1 |

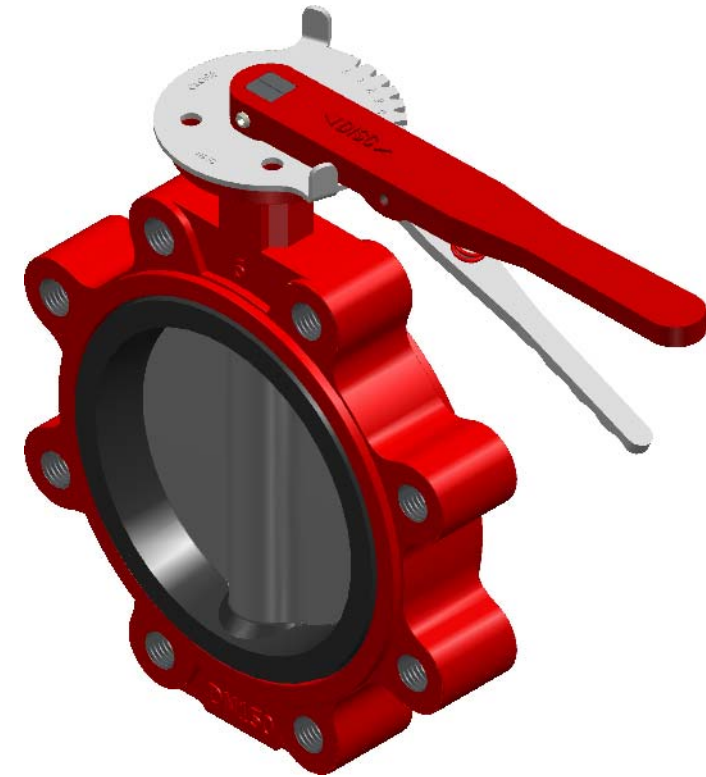
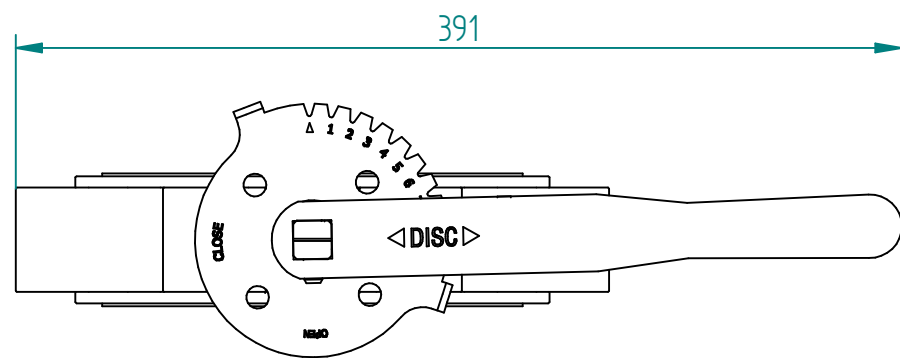

| | | NAME | DATE | SIZE | DWG NO |
|-------|----------|------|------------|---------------------------------|------------------|
| TITLE | DRAWN | AXJO | 23.04.2026 | A3 | AMX-110-061-0150 |
| | CHECKED | TOCO | dd.mm.yyyy | FILE NAME: AMX-110-061-0150.dft | |
| | ENG APPR | TOCO | dd.mm.yyyy | SCALE: 1:3,33 | REV: 00 |
| | MGR APPR | TOCO | dd.mm.yyyy | WEIGHT: 10,119 kg | SHEET: 1 OF 1 |

UNLESS OTHERWISE SPECIFIED DIMENSIONS ARE IN MILLIMETERS AND TOLERANCES ARE +/-0,5

| REV | DESCRIPTION | DATE | APPROVED |
|------------------|-------------|------------|----------|
| 00 | First issue | 23.04.2026 | AXJO |
| REVISION HISTORY | | | |